



SILK WAY RALLY 2017 丝绸之路



MEDIA REGULATIONS

Media Accreditation Process on
International Silk Way Rally 2017
Russia - Kazakhstan - China

7-22 July, 2017



SUMMARY

General conditions	Page 2
.....	
Permanent accreditation INDIVIDUAL PRESS CAR PACK	Page 4
Permanent INDIVIDUAL PRESS ACCREDITATION PLANE/BUS	Page 12
Permanent INDIVIDUAL PRESS ACCREDITATION SERVICE VEHICLE	Page 14
Technical Requirements for sending Videos	Page 16
Technical requirements for your Laptop	Page 16
DAILY ACCREDITATION	Page 17
.....	
Contacts	Page 18
.....	

GENERAL CONDITIONS

The SILK WAY RALLY 2017 will be held from 7th to 22nd July 2017 on the territories of Russia, Kazakhstan and China.

Administrative checks and scrutineering will take place in Moscow on July 5th and 6th, 2017.

Only the French version of these current regulations will be binding. Russian, English and Chinese translations are available.

4 DIFFERENT TYPES OF PRESS ACCREDITATIONS

1 Permanent accreditation «INDIVIDUAL PRESS CAR PACK»

On a press car (not provided by the organisation) from 7th to 22nd July 2017.

2 Permanent accreditation «INDIVIDUAL PRESS ACCREDITATION PLANE / BUS»

By plane/bus chartered by the organisation, from Moscow to Xi'An, from 7th to 22nd July 2017 .

The number of these permanent accreditations is limited.

3 Permanent accreditation «INDIVIDUAL PRESS ACCREDITATION SERVICE VEHICLE»

Media or Team representative is transported aboard a Team's vehicle, from 7th to 22nd July 2017.

4 Daily accreditation

For all accredited journalists and photographers wishing to come for one up to five stages.

CAUTION: it is impossible to get an accreditation for more than **5** cumulated stages.

The permanent accreditations are valid for the whole rally. No change of name will be possible during the rally.

The organizing committee reserves the right to accept or refuse any request for accreditation.

PRESS ROOMS

Fully equipped press rooms (tables, chairs, lights, electrical plugs, internet wired connections for photographers duly accredited...) will be available for **PERMANENT** accredited journalists on all bivouacs.

AVAILABLE INFORMATION

All press information will be available and released by the press department in Russian, French, English and Chinese: race news, competitors' positioning during the special stages, classifications, retirements, press releases, interviews.

Information will be posted on boards, on screens and on the rally's intranet.

Access to INTERNET will be provided by MARLINK EVENTS SAS (check technical specifications page 15). It is important to contact MARLINK EVENTS SAS for the setting up of your computer during administrative checks, in Moscow.

TRANSMISSIONS

From Moscow to Xi'An

A Wi-Fi system will be available in the press center, reserved to PERMANENT ACCREDITATIONS. Journalists wishing to have a specific line have to contact the rally press department:

m.belenotero@yahoo.com.ar



On bivouacs

Internet will be available every day as soon as the media center is set up and will work until 10.00 pm.

Neither the organisers nor MARLINK EVENTS SAS will supply computers nor printers. All journalists and press officers are expected to provide their own equipment which should be insured.

ACCOMMODATION AND CATERING

Some bivouacs may be located close to cities. On these bivouacs, participants wishing to stay in hotels may easily book one by themselves. Otherwise, it will of course be possible to sleep in an individual tent (no provided by the organizers) on the bivouacs.

Catering on the bivouac is included in ALL PERMANENT PACKS from 8th to 21st July (breakfast, lunch-pack/lunch, dinner), 22nd (breakfast).

People having Daily Accreditations ARE NOT allowed to benefit from the bivouac's catering.

NON RESPECT OF REGULATIONS

Failure to respect the regulations in any way by any accredited person, will automatically lead to his/her exclusion from the event. This could lead to the exclusion of the entire crew (all occupants of a same vehicle).

DRIVER'S CODE GENERAL

Vehicles and persons registered in press cars are obliged to behave with respect and courtesy on the road and towards:

- the population of the countries crossed,
- the other competitors,
- the members of the organisation.

Any impoliteness which is proven will be subject to a penalty of €500.

ASSISTANCE/SERVICE TO A COMPETITOR

A person having a press accreditation for the SILK WAY RALLY 2017 (except if entered in a service vehicle) is not allowed to help in whatever manner a competitor of the race: transporting spare parts, giving fuel, transporting bivouac material, helping out on with mechanical problems, etc...

If such is the case, this person could be expelled from the rally and involve the forced withdrawal from the race of the concerned competitor.

PERMANENT ACCREDITATION «INDIVIDUAL PRESS CAR PACK»

Full payment of the INDIVIDUAL PRESS CAR PACK fees must be done right after you receive the confirmation of your accreditation from the organisers and before 1st June 2017.

Due to administrative requirements linked to the crossing of China, no change of name nor of vehicle will be taken into account from 1st June 2017.

Press vehicles are subdivided into two categories:

1. **Press cars following the race route.**
2. **Press cars following the service route only.**

All press cars (not provided by organisers) must compulsorily pass administrative and technical checks in Moscow (on 5th July afternoon or 6th July 2017), to be checked before the start. Vehicles not equipped with safety equipment mentioned below will not be allowed to start.

Accreditation Fee : 3.500 € /

Depending on the type of vehicle entered, a press car crew must be composed of a minimum of two people and a maximum of 5.

Only four-door 4x4s will be allowed to transport more than 2 persons.

Only vehicles authorized by registration certificates will be allowed to carry 5 persons.

No changing and/or swapping of occupants will be authorised once the crew has been checked at scrutineering. If a member of the crew leaves his vehicle as a result of unforeseen circumstances the vehicle may continue, on condition that the organisation is informed of this and agrees. Under no circumstances may this member of the crew be replaced.

The number of press cars being allowed on the race route is limited (priority will be given to TV cars and photographers)

The organizing committee reserves the right to accept or refuse any request for accreditation.

This rate includes

- Meals at the bivouacs from July 8th to 22nd morning (breakfast, ration/lunch, dinner).
- Race and/or service Road Book, media-guide and other documentation.
- Internet connection in the press center during the rally (traffic limits are fixed by the organizers).
- Insurance and medical repatriation.
- Third party liability insurance.
- Access to Prize Giving ceremony.
- **Rental of the GPS - Tripy (compulsory for service route).**
- **Rental of the GPS - Sentinel UNIK II (compulsory for race route).**
- **Rental of the Iritrack (compulsory for race route).**

This rate does not include

- Flight to Moscow and from Xi'An
- Accommodation at start in Moscow and at finish in Xi'An
- Meals in Moscow and Xi'An
- Travel expenses
- Fuel
- Vehicle transportation to Moscow and from Xi'An
- Phone calls
- Tent and sleeping bag to sleep on the bivouacs.
- Visa expenses
- Rental or purchase of satellite phone (optional)

Requests for permanent accreditation «INDIVIDUAL PRESS CAR PACK» must be done on the online registrations' platform of the rally's website (www.silkwayrally.com), on 1st June 2017 at the very latest. After this date, it will no longer be possible to make a request for accreditation.

When you will be making your request for permanent accreditation «INDIVIDUAL PRESS CAR PACK» on the online platform, you will have to provide copies of the following documents and to fill in all requested details, regarding people and vehicles:

- Copy of press card (editorial card) of accredited journalists, photographers.
- Colour photo 3x4 for each crew member (less than 6 months).
- Copies of passport.
- Copies of driver's license.
- Copy of car registration certificate.
- Copy of car insurance documents, which must be valid and operating in the 3 countries crossed (otherwise, a special stand will be available at administrative checks).
- Authorization from the owner of the vehicle, if the latest is not part of the crew.
- 5 photos of the vehicle entered (see details on the platform when registering).

Organisers will confirm permanent accreditation «INDIVIDUAL PRESS CAR PACK» **before 20th June 2017.**

ADMINISTRATIVE OBLIGATIONS

Each journalist, photographer or press officer benefiting from a permanent accreditation «INDIVIDUAL PRESS CAR PACK» must compulsorily be present at the administrative checks in Moscow, on 5th July afternoon or 6th July 2017 and must present the valid documents above mentioned, in their original form.

Any original document missing at administrative checks and/or scrutineering, will lead to a refusal of entry for the journalist / photographer / press officer.

No photocopies or declaration of loss and/or theft will be accepted.

Depending on the type of vehicle entered, a press car crew must be made up of a minimum of two people and a maximum of five people. Only five-door 4x4s will be allowed to transport more than 2 persons (it is mandatory to present a vehicle registration certificate). Only vehicles authorized by registration certificates will be allowed to carry 5 persons.

No changing and/or swapping of occupants will be authorized after 1st June 2017.

If a member of the crew leaves his vehicle as a result of unforeseen circumstances the vehicle may continue the rally on condition that the organisation is informed of this and agrees.

Press cards will be required for all occupants of the vehicle except for the driver, but he must prove his off-road driving capacities by showing a proof (see appendix: INDIVIDUAL PRESS CAR PACK).

ITINERARY

Press vehicles will be decorated with stickers of the rally colours during scrutineering, by the organisers.

This will allow them to follow the race route of rally (green stickers) or the service route (yellow stickers), to access dedicated car parks and bivouacs with their vehicles.

PRESS VEHICLES

Press vehicles following the race route (green stickers) are allowed to drive on the itinerary of their choice: race or service.

Every day the code corresponding to the selected itinerary (race or service) must be entered in the GPS.

Press cars with yellow stickers must drive on the service route ONLY. For safety reasons, they may in no case drive on the race route, except upon exceptional authorisation of the organisers.

Not respecting this rule will lead to the withdrawal of the accreditation (removal of stickers). The vehicle will thus not be allowed to enter the bivouacs, neither to transport persons accredited on the rally.

According to the circumstances of the infringement, accreditations of the passengers entered in this vehicle may be withdrawn as well, even if these persons were not inside the vehicle during the infringement.

CAUTION: IN ORDER TO ENTER THE RACE ROUTE, IT IS MANDATORY TO ENTER THE SPECIAL STAGE AT THE LATEST ONE HOUR BEFORE THE START OF THE FIRST COMPETITOR.

CARS WILL NOT BE ALLOWED TO ENTER THE ROUTE AFTER THAT TIME.

ROAD-BOOKS AND INSTRUMENTS

Accredited press vehicles may follow the entire rally and will get the following road books:

- ⇒ «**Service**» Road-Book: they will be distributed during administrative checks in Moscow. All vehicles following the service route will be equipped with an automatic road book reader (Tripy).
- ⇒ «**Race**» Road-Book: they will be distributed daily, the night before for the following day, at the time control at the entrance of the bivouac. This allows press cars to follow the race route. The one for the 1st stage will be given during the press briefing.

If a press vehicle wishes to move ahead on the route, «race» road-books may be distributed in advance. A specific request must be made to the press department and accepted by both press and sporting departments.

Iritrack will be used as a positioning system.

Every day press cars **MUST** allow the control of their **GPS (Tripy or ERTF)** at the entrance of bivouac.

Any refusal to sign will lead to the following penalties:

- **1st refusal: vehicle blocked at TC,**
- **2nd refusal: penalty up to and including exclusion.**

However, refusal to sign will not prevent the application of penalty(ies).

TRAFFIC / SPEED

1) Throughout the entire Event, crews must strictly observe the traffic laws of the countries crossed, as well as road signs. In the case of infringement and police control, crews will be fully responsible for the facts they have been arrested for. Any fines will be combined with penalties for non-compliance with the speed limits.

2) In Russia and in Kazakhstan all vehicles (race and service) must drive with lights on, at any time (road sections and selective sections).

3) Radar controls will be carried out along the itinerary by local police forces.

4) The registration plate must be affixed at the front and at the rear of the vehicle and the number must be legible.

5) All crews not respecting the traffic laws of the countries crossed (driving at an excessive speed or behaving in a dangerous manner) and which are subject to a police report risk penalties up to exclusion.

MAXIMUM SPEED

1) In addition to the speed control zones, the maximum speed will be limited and controlled by the GPS (TRIPY or ERTF) throughout the road sections, except in cases detailed on a bulletin and/or on the road book. The maximum speed authorized will be those allowed by the Traffic Laws of the countries being crossed.

2) In Russia, on roads and outside selective sections, speed is limited to:

- **70 kph for trucks,**
- **90 kph for cars.**

In Kazakhstan, on roads and outside selective sections, speed is limited to:

- **70 kph for trucks,**
- **100 kph for cars.**

In China, on roads and outside selective sections, speed is limited to:

- **100 kph for trucks,**
- **120 kph for cars.**

If the local speed limit is lower, it applies.

3) When overspeeding a sign will appear on the screen of the GPS, together with an aural signal.

The GPS will be controlled when entering the bivouacs, the information being automatically transmitted by radio. In the case of an infringement, the person carrying out the checks will note any infractions which will be counter signed by a crew member.

4) When overspeeding, the GPS records the length of the overspeeding, as well as its value.

Any overspeeding will lead to the following penalties:

- **from 1 to 20 kph :**
 - **fine of 100 € by infraction, between 00 and 500 meters of overspeeding**
 - **fine of 400 € by infraction, over 500 meters of overspeeding**
- **from 21 to 40 kph :**
 - **fine of 600 € par infraction, between 00 and 500 meters of overspeeding**
 - **fine of 1.000 € by infraction, over 500 meters of overspeeding + exclusion of the vehicle and of its crew**
 - **These penalties come in addition to those imposed for an overspeeding from 1 to 20 kph.**
- **over 40 kph :**
 - **fine of 1.000 € minimum + exclusion of the vehicle and of its crew + 5-minute-penalty for the best ranked vehicle of the team**
 - **In the case of repeated action by an other vehicle of the same team : penalty that may go as far as exclusion of the best ranked vehicle of the team.**

The fine should be paid within 24h00 after notification, under pain of exclusion of the vehicle and of its crew.

SPEED CONTROL ZONES

1) There will be speed control zones on the itinerary, in villages, on roads or tracks etc. They will be indicated on the road-book and controlled by the GPS (TRIPY or ERTF).

When crossing these zones, press cars must respect the speed indicated on the road-book.

2) Any overspeeding in the same zone will be considered as a single infraction. An infraction is composed of one or several overspeedings in the same speed control zone. Any overspeeding in another zone will result in a second infraction.

3) Any overspeeding will lead to the following penalties:

- **from 1 to 20 kph :**
 - **fine of 100 € by infraction, between 00 and 200 meters of overspeeding**
 - **fine of 400 € by infraction, over 200 meters of overspeeding**
- **from 21 to 40 kph :**
 - **fine of 600 € par infraction, between 00 and 200 meters of overspeeding**
 - **fine of 1.000 € by infraction, over 200 meters of overspeeding + exclusion of the vehicle and of its crew**
 - **These penalties come in addition to those imposed for an overspeeding from 1 to 20 kph.**
- **over 40 kph :**
 - **fine of 1.000 € minimum + exclusion of the vehicle and of its crew + 5-minute-penalty for the best ranked vehicle of the team**
 - **In the case of repeated action by an other vehicle of the same team : penalty that may go as far as exclusion of the best ranked vehicle of the team.**

The fine should be paid within 24h00 after notification, under pain of exclusion of the vehicle.

SPEED BIVOUAC / STAGE TOWN

It is forbidden to, under risk of penalty up to and including exclusion:

- drive at excessive speed (more than 30km/h) within the bivouac area,
- drive dangerously in the area of the bivouac or in stage towns where local speed limits must be respected),
- drive on airstrips.

TRAFFIC

U-turns are forbidden on the race track.

To take pictures or to film, you must park several meters from the track where you will not obstruct the passage of the competitors.

SENTINEL SYSTEM OF THE GPS (race route only)

To increase safety when over passing on the track, the **SENTINEL** function of the GPS is mandatory for vehicles following the race track.

It is a warning system that indicates when a vehicle is overpassing. As soon as you receive the warning signal from a competitor who is behind you (light/sound) you respond to the signal and you move to the side of the track to allow the competitor to pass you.

ALCOHOL DRIVING: NO TOLERANCE AT ALL !!

The participants settle themselves their problems with the State Traffic Safety Inspectorate of Russian Federation, Traffic police of Republic of Kazakhstan and Traffic Police of the People's Republic of China.

It is necessary to take into account that for malicious infringements of traffic regulations (driving in a drunken state, driving on a lane of oncoming traffic in the places forbidden for this purpose, infringement of overtaking rules etc.) the Russian, Kazakh and Chinese legislations provide strict sanctions up to arrest and imprisonment. Penalties of the State Traffic Safety Inspectorate and Rally Direction are not interconnected.

IDENTIFICATION AND MARKINGS

The organisation will supply the following for all vehicles during scrutineering:

- 1)** 1 windscreen strip 25 cm from windscreen stop on each side, 10 cm high.
- 2)** 2 rally plates measuring 43x21,5 cm at front and rear, compulsory.
- 3)** 3 race plates measuring, 50x52 cm.
- 4)** 2 advertising plates, measuring 50x52 cm.

Traditional 4x4 vehicles

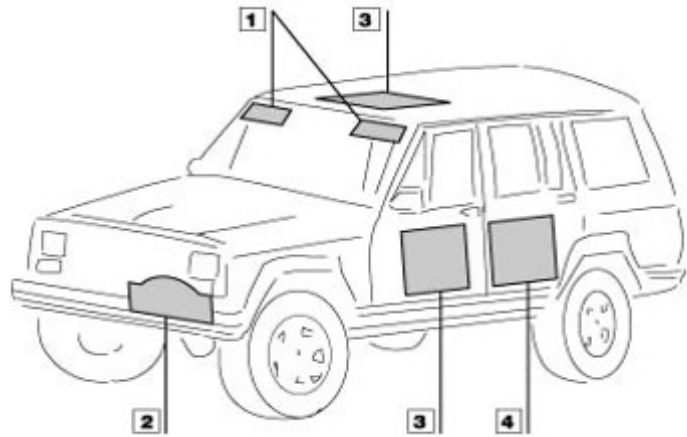

TECHNICAL REGULATIONS FOR PRESS VEHICLES

Are allowed standard 4x4 (petrol or gasoline powered) in accordance with the T2 regulations (standard vehicles).

It is not necessary for press vehicles to be homologated by the F.I.A. However, cars must comply with all of the safety norms of the technical regulations for the Production category (T2).

These technical regulations may be consulted on the website: www.fia.com.

Maximum height of cars (roof rack included): 2,50 m,

Fuel tank sufficient for 800 km: the spare tank(s) for petrol-engined vehicles must be of FT3 type. Diesel fuel tanks must be made and marked by an approved fuel tank manufacturer.

NB: fuel tanks must be filled from outside the vehicle. Pipes, mountings and vents must conform to the technical regulations for off road vehicles.

Up to the start, organizers reserve the right to refuse every vehicle which would not appear as adapted.



➤ **ROLL BARS (only for vehicles following the race route)**

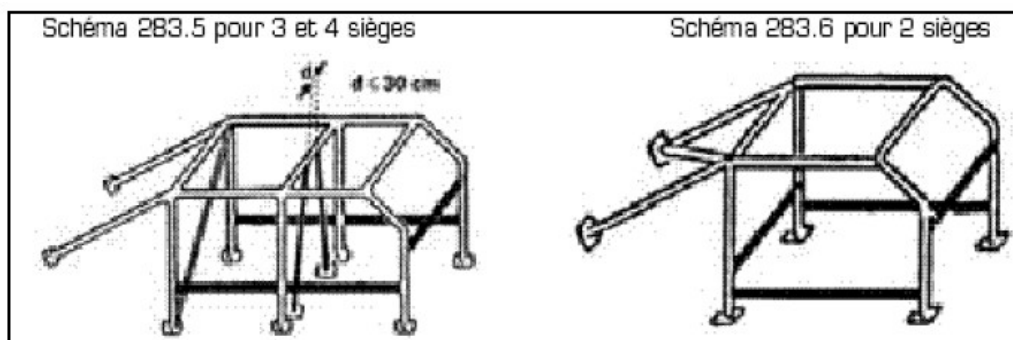

- Roll bars must correspond to F.I.A. norms: diameter, 50 mm - minimum thickness, 2 mm - Material: cold drawn seamless carbon steel - Bolts must be at least size 8 and comply with ISO 8.8 standard norms. Anchorage points and structures.

➤ **TRACK CLOSURE**

- Organisation «sweeping trucks» will close the rally route.
- It is impossible to guarantee that the sweeping truck will pass the exact spot where a vehicle has broken down. It is therefore up to the crew to signal their presence with their satellite telephone or their Iritrack. The sweeping trucks will transport all occupants of broken-down vehicles and will tow the broken down vehicles up to the next road at the minimum, whenever possible. Recuperation of the vehicle is then at the crew's expense.
- Sweeping trucks may ensure the recovery of broken-down or accidented vehicles, only if the latest are located on the itinerary of the road-book. If the sweeping truck cannot reach the position of the broken-down or accidented vehicle, crew will thus be in charge of the recovery of their vehicle on the track. They may get all necessary information to recover their vehicle from the press department.
- Crew members who refuse to board the sweeping vehicle do so at their own risk, and must sign a discharge that will be presented to them by the members of the organisation in charge of closing the track. No further recourse may be taken against the organisation as a consequence of this refusal once the discharge has been signed.

➤ **SECURITY**



- **For your own safety, it is strongly recommended to wear a helmet on the race track and wearing a safety harness is compulsory throughout the entire route.**





➤ **LOSS OF VEHICLE (complete or partial destruction)**

➤ **1)** If a vehicle is lost (accident, fire, destruction etc.), the crew must make a statement to the police or customs. This statement must contain the facts of what happened, the registration number, the race number, and the contact details of the people involved etc. A copy of this statement must be provided to the organisers.



➤ **2)** The participant must contact the organization to know what to do, according to the place of retirement.

➤ The vehicle must be returned to Xi'An or Moscow where the local authorities will decide, depending on the state of the vehicle, whether it should be re-exported, destroyed, or whether cancellation of its temporary import is justified. Any additional repatriation costs must be paid by the crew.



➤ **3)** In addition to the risks incurred locally by failure to comply with the rules in force (fines, impoundment of vehicle / passengers, etc.), any crew found to have breached this rule will get a fine of 1.500 €.



➤ **RESPECT SENSITIVE AREAS**

➤ **1)** In agricultural or forest areas, populated zones or zones that are sensitive from a safety stand point, the itinerary and all the boxes of the road book must be scrupulously followed. In particular it is forbidden to 'cut' corners by crossing fields, forests, orchards or marshes:

■ 1st infringement: 1.000 €

■ Repeat offence: exclusion



➤ **2)** So as to respect the crossed areas, it is forbidden to destroy the fences' gates located along the route. Judges of fact will be on spot.

➤ **All broken fences' gate will result in a penalty of €1.000. In case a gate, a fence etc. is destroyed, the crew is liable for all costs incurred.**

➤ **All repeated offence will result in a penalty up to and including exclusion.**



➤ **3)** It is forbidden to leave wheels or punctured or damaged tyres on the itinerary of the route. Any crew caught disobeying this rule will be penalised 1.000 € per tyre or wheel. Repeat offending will result in penalties up to and including exclusion.

➤ PERMANENT ACCREDITATION
➤ « INDIVIDUAL PRESS ACCREDITATION
PLANE/BUS »

-
-
- Full payment of the INDIVIDUAL PRESS ACCREDITATION PLANE/BUS fees must be done right after you receive the confirmation of your accreditation from the organisers and before 1st June 2017.
-
- **Due to administrative requirements linked to the crossing of China, no change of name will be taken into account from 1st June 2017.**
-
- The press plane is exclusively reserved for **permanent accredited** (media and press officers).
-
- **IMPORTANT:** Any accredited person who decides not to travel aboard the press plane on some stages, must necessarily warn the people in charge of the Press Office 48 hours before (see Contacts).
- Beyond two breaches of this rule, the person concerned will be erased from the lists that enable the daily access to transportation means provided by the organizers.

Accreditation Fee : 6.000 € /

-
-
-
-
-
-
-
-
- Number of seats is restricted.
- **The organisers reserve the right to accept or refuse any request for accreditation.**
-
- **➤ This rate includes**
-
- - Plane transfer on the whole rally itinerary from Moscow to Xi'An from July 8th to 22nd 2017.
- - Access to the rally press center on start / finish and on the bivouacs.
- - Meals at the bivouacs from July 8th to 22nd morning (breakfast, ration/lunch, dinner).
- - Media-guide and other documentation.
- - Internet connection during the rally (traffic limits are fixed by the organizers).
- - Insurance and medical repatriation.
- - Third party liability insurance.
- - Access to the Prize Giving ceremony
-
- **➤ This rate does not include**
-
- - Flight to Moscow and from Xi'An
- - Accommodation at start in Moscow and at finish in Xi'An
- - Meals in Moscow and Xi'An
- - Travel expenses
- - Fuel
- - Phone calls
- - Tent and sleeping bag to sleep on the bivouacs.
- - Visa expenses
- - Purchase or rental of satellite phone (optional)

- **Requests for permanent accreditation INDIVIDUAL PRESS ACCREDITATION PLANE/BUS must be done on the online platform of the rally's website: www.silkwayrally.com, before 1st June at the very latest. After this date, it will no longer be possible to make a request for accreditation.**
-
- Mandatory administrative checks for all journalists will be organized on 5th July afternoon and 6th July 2017, in Moscow.
-

- When you will be making your request for permanent accreditation **INDIVIDUAL PRESS ACCREDITATION PLANE/BUS** on the internet platform, you will have to provide copies of the following documents and to fill in all requested details, regarding people and vehicles:
- **Copy of press card (editorial card) of accredited journalists, photographers.**
- **Colour photo 3x4 for each crew member (less than 6 months).**
- **Copies of passport.**
 - Organisers will confirm permanent accreditation «INDIVIDUAL PRESS ACCREDITATION PLANE/BUS» **before 20th June 2017.**
 - Each journalist, photographer, press officer must show his/her valid passport and press card at administrative checks on 5th July afternoon or 6th July, in Moscow.
 - Any original document missing at administrative and technical checks, will lead to a refusal of accreditation for the journalist / photographer / press officer.
 - No photocopy or declaration of loss and/or theft will be accepted.
 -
 -
 - **LUGGAGE**
 - It is strictly forbidden to transport in one's luggage, spare parts, tools, a competitor's personal belonging under penalty of cancellation of accreditation and exclusion from the rally of the persons concerned (journalist and competitor).
 - The maximum authorised weight per person is 23 kg, including only 1 bag, the sleeping bag and the tent.
 - You will travel on regular flights as well and be submitted to safety checks as in a national airport.
 -
 -
 -
 -
 -
 -
 -
 -
 -
 -
 -
 -
 -
 -
 -
 -
 -
 -
 -
 -
 -
 -
 -
 -

➤

➤ **PERMANENT ACCREDITATION**

➤ **«INDIVIDUAL PRESS ACCREDITATION SERVICE VEHICLE»**

➤ Full payment of the INDIVIDUAL PRESS ACCREDITATION SERVICE VEHICLE fees must be done right after you receive the confirmation of your accreditation from the organisers and before 1st June 2017.

➤ **Due to administrative requirements linked to the crossing of China, no change of name will be taken into account from 1st June 2017.**

➤ By the term INDIVIDUAL PRESS ACCREDITATION SERVICE VEHICLE are concerned journalists, photographers of media or teams press officers transported aboard a service vehicle.

Accreditation Fee : 3.500 € /

➤ **Organisers reserve the right to accept or refuse any request for accreditation.**

➤ **This rate includes**

- - Plane/Bus transfer on the whole rally itinerary from Moscow to Xi'An from July 8th to 22nd 2017.
- - Access to the rally press center on start / finish and on the bivouacs.
- - Meals at the bivouacs from July 8th to 22nd morning (breakfast, ration/lunch, dinner).
- - Media-guide and other documentation.
- - Internet connection during the rally (traffic limits are fixed by the organizers).
- - Insurance and medical repatriation.
- - Third party liability insurance.
- - Access to the Prize Giving ceremony.

➤ **This rate does not include**

- - Flight to Moscow and from Xi'An
- - Accommodation at start in Moscow and at finish in Xi'An
- - Meals in Moscow and Xi'An
- - Travel expenses
- - Fuel
- - Costs linked to the Vehicle
- - Phone calls
- - Tent and sleeping bag to sleep on the bivouacs.
- - Visa expenses
- - Purchase or rental of satellite phone (optional)

- **Requests for permanent accreditation INDIVIDUAL PRESS ACCREDITATION SERVICE VEHICLE must be done on the online platform of the rally's website: www.silkwayrally.com, before 15th May 2017, at the very latest. After this date, it will no longer be possible to make a request for accreditation.**
- **When you will be making your request for permanent accreditation INDIVIDUAL PRESS ACCREDITATION SERVICE VEHICLE on the internet platform, you will have to provide copies of the following documents and to fill in all requested details, regarding people and vehicles:**
- **Copy of press card (editorial card) of accredited journalists, photographers.**
- **Colour photo 3x4 for each crew member (less than 6 months).**
- **Copies of passport.**
- Organisers will confirm permanent accreditation « INDIVIDUAL PRESS ACCREDITATION SERVICE VEHICLE » **before 20th June 2017.**
-
-
- Each journalist, photographer, press officer must show his/her valid passport and press card at administrative checks on 5th July afternoon or 6th July, in Moscow.
- Any original document missing at administrative and technical checks, will lead to a refusal of accreditation for the journalist / photographer / press officer.
- No photocopy or declaration of loss and/or theft will be accepted.
-
-
- **ASSISTANCE/SERVICE TO A COMPETITOR**
- Any person having an INDIVIDUAL PRESS ACCREDITATION SERVICE VEHICLE is allowed to carry out service on a vehicle's competitor, with the same limits as people entered in the SERVICE CATEGORY.
-



➤ TECHNICAL REQUIREMENTS FOR SENDING VIDEOS

-
- Format: MP4
- Codec: h264
- Resolution: 568 x 320 or 480 x 272
- Number of frames per second: 25
- Quality: full
- Video bitrate: 1500 Kbps
- Audio: MPEG AAC Audio (mp4a),
- Frequency: 44100 Hz
- Audio codec: mp3 or AAC - stereo
- Audio bitrate: 96 kbps
-
-

➤ TECHNICAL REQUIREMENTS FOR YOUR LAPTOP

-
- Please see below for technical requirements for your computer if you need to be connected to the race network.
-
- **Please note:** we will modify the configuration of your laptop in order to connect you to the local network. If your system is protected by a user name or password, please contact your administrator who will provide you with a user name and "administrator" password.
-

➤ **Your computer must meet the following requirements:**

➤ **PC**

- Minimum processor : 32bits or 64 bits 1Ghz
- RAM: min. 1Go (32bits) or 2Go (64bits)
- Disk Space: 40Go
- Network card : 100/1000 RJ45, 2.4 Ghz Wi-Fi b/g/n or 5 Ghz an/ac
- Operating system: Win7/Win8/Win10, Linux
- Browser up-to-date : IE11, Firefox, Chrome, Edge, others.

➤ **Administrators rights**

➤

➤

➤ **APPLE**

- Type: MacBook / MacBook Pro
- RAM: min 2Go
- Disk space : 40Go
- Network card : 100/1000 RJ45, 2.4 Ghz Wi-Fi b/g/n or 5 Ghz an/ac
- Operating system: OS X
- Browser up-to-date: Safari, Firefox, Chrome

➤ **Administrators rights**

➤

➤

➤ **Your system must be protected by up-to-date antivirus software.**

➤ **You are advised to purchase a cable lock for your computer.**

➤

➤

➤

➤ DAILY ACCREDITATION

- Requests for daily accreditation must be sent to organisers before 1st June 2017, at the latest.
- **Number of daily accreditations for one media is restricted and cannot exceed 5 legs.**
- Request for daily accreditation at start and/or finish and/or bivouac along the rally itinerary should be accompanied by the copy of press card and/or editorial card is compulsory.
 - Accreditation provides a daily access to:
 - ⇒ Bivouacs (without food)
 - ⇒ Spaces for competitors
 - ⇒ Press information (dedicated area, no access to the Media Center)
 - ⇒ Podiums (dedicated area)
 - Accreditations do not include:
 - ⇒ Transportation between bivouacs (neither insured nor supported by the organization).
 - ⇒ Catering at the bivouacs..
 - ⇒ Access to the race route (it is strictly prohibited).
 - ⇒ Transmissions' costs.
 - The organizing committee does not provide computers nor any other office equipment.
- **CAUTION:** It's impossible to obtain daily accreditations for more than **5 cumulated legs**.
- Are considered as one leg:
 - ⇒ Administrative checks, scrutineering and start podium (5th, 6th and 7th July)
 - ⇒ Any entire leg, starting from the morning and finishing at night
 - ⇒ Urumqi's bivouac, upon arrival of the leg on 15th July, as well as on the rest day, on 16th July
 - ⇒ Finish podium, 22nd July
-
-

➤ CONTACTS

➤ **PRESS CENTER OF
THE SILK WAY RALLY**

➤ **RUSSIA and KAZAKHSTAN**
➤ **Erik Khayrullin**
➤ E-mail: media@silkwayrally.ru

➤ **Evgeniya Bykova**
➤ E-mail: press@silkwayrally.ru
➤ Tél. +7 (8552) 37 26 14

➤ **INTERNATIONAL**
➤ **Chris Rodrigo**
➤ E-mail: crodrigo@silkwayrally.ru
➤ Tel +33(0)607226233
➤ **Belen Otero**
➤ m.belenotero@yahoo.com.ar

➤ **CHINA**
➤ **Kathy Li Hui**
➤ E-mail: kathylihui@126.com

➤ **TRIPY SA**
➤ (Service GPS)

➤ E-mail: silkwayrally@tripy.be
➤ Phone: + 32 (0)71 34 74 90
➤ Fax: + 32 (0)71 34 73 99

➤ Faubourg de Bruxelles, 320
➤ Gosselies 6041 - Belgium

➤ **ERTF**

➤ (Race GPS + Sentinel)

➤ **Cathy Tournaire**
➤ E-mail: competition@ertf.com
➤ Tél: +33 (0) 2 97 87 25 85
➤ Parc Technologique de Soye
➤ 56 275 Ploemeur - France

➤ **MARLINK EVENTS SAS -
RALLY RAID DEPARTMENT**
➤ (Iritrack & Satellite Phone)

➤ **Mehdi Couillard**
➤ Email:
➤ mehdi.couillard@marlink.com
➤ Tel: +33 (0)1 48 84 34 07

➤ 114 / 126, avenue d'Alfortville
➤ 94600 Choisy le Roi - FRANCE
➤ Tél. : +33 (0)1 48 84 34 00
➤ Fax : +33 (0)1 48 52 53 54